

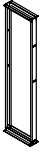









Item #	Illustration	Part Number	Qty.	Extra	Item #	Illustration	Part Number	Qty.	Extra
1		<b>10-00126-084</b> Super Relay Rack Frame Kit	2		6		<b>83-28004-005</b> 1/4" Washer-Zinc Plated	4	4
2		<b>82-04040-750</b> Super Relay Rack 24" Leg	2		7		<b>83-28002-005</b> Kep Nuts-1/4-20	20	4
3		<b>82-04040-730</b> Leg Stretcher for 19" Super Relay Rack	1		8		<b>83-28003-015</b> 1/4-20 x 3/4" Steel Carriage Bolt Black Oxide	8	4
4		<b>82-04040-705</b> Reinforcement Plate for Uprights	2		9		<b>28-00110-000</b> Glider	4	
5		<b>83-28001-034</b> 1/4-20 x 5/8" Button Head Socket Cap Screw-Steel	12	4	10		<b>82-04040-795</b> Extender, Inner Angle	2	

**Step 1. Assemble Base**



**Note:** See page 2 of 2 for Frame Assembly

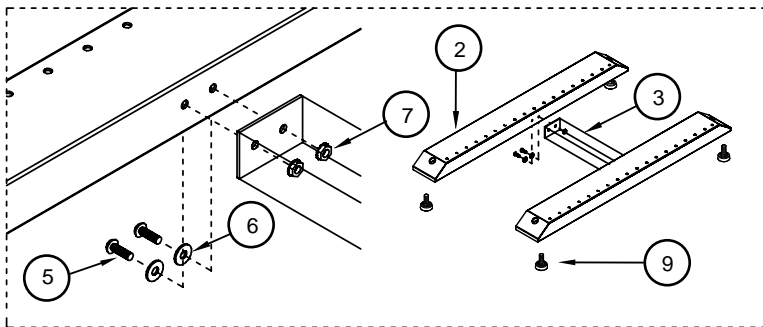

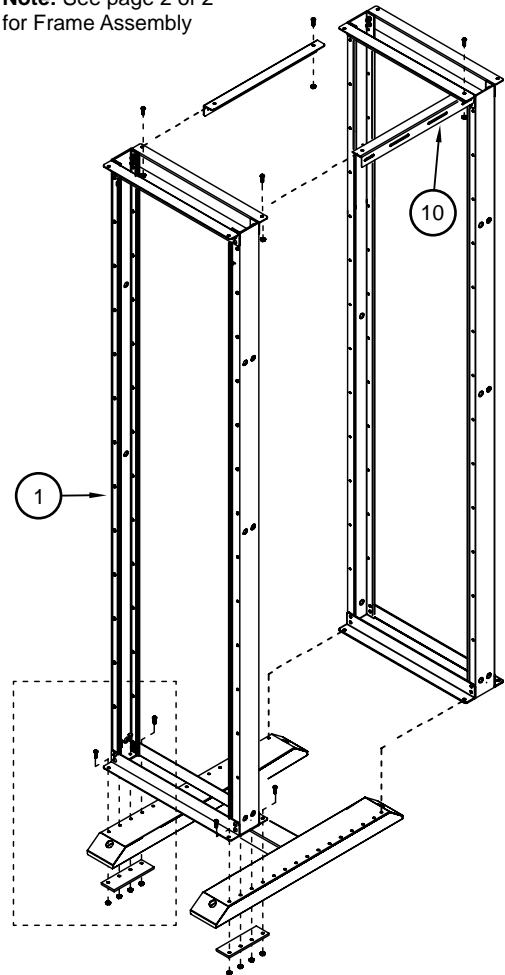
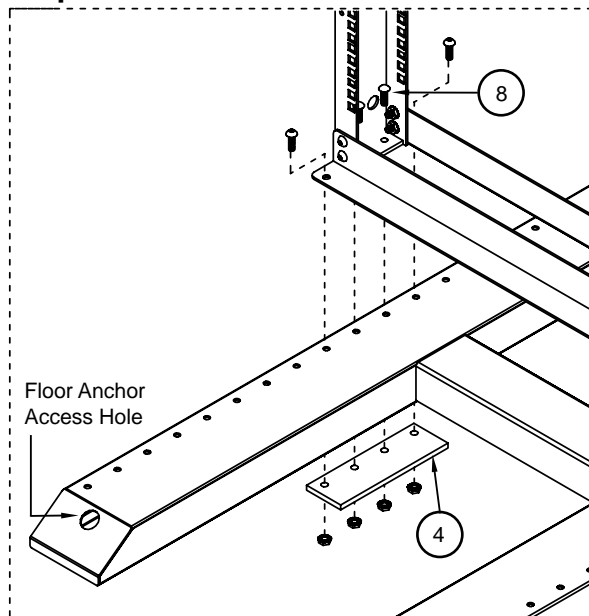

**Step 2. Mount Frames to Base**



UNLESS OTHERWISE SPECIFIED  
 DIMENSIONS ARE IN INCHES  
 TOLERANCES  
 2 PL DECIMALS ± .01  
 3 PL DECIMALS ± .005

NEXT ASS'Y:

DATE: 08/10/06

Item #	Illustration	Part Number	Qty.
1		<b>82-04040-700</b> Upright for Super Relay Rack	2
2		<b>82-04040-710</b> Uprights Stretcher for 19" Super Relay Rack	4
3		<b>83-28001-034</b> 1/4-20 x 5/8" Button Head Socket Cap Screw-Steel	16
4		<b>83-28002-005</b> Kep Nuts 1/4-20	16

